

p/n: 00GSE-1023-00

Transfiller Adapter, CGA-540N to DIN-477-9S



Aviation Oxygen Systems

MOUNTAIN HIGH
Equipment & Supply Company

Date:

Cleaned for Oxygen Service per MH ESR-008D

REV	ECO	Release	Drawn	REVISION HISTORY
-1	2018-022	2018-08-03	SGO	Customer Drawing

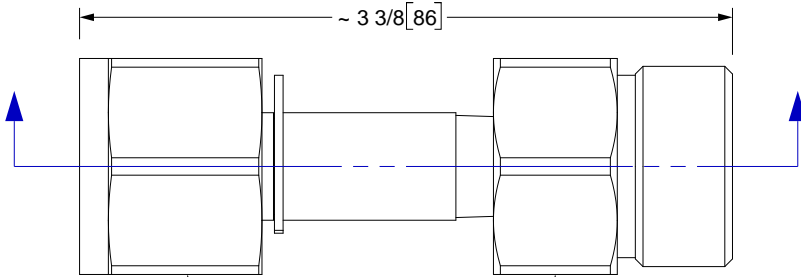
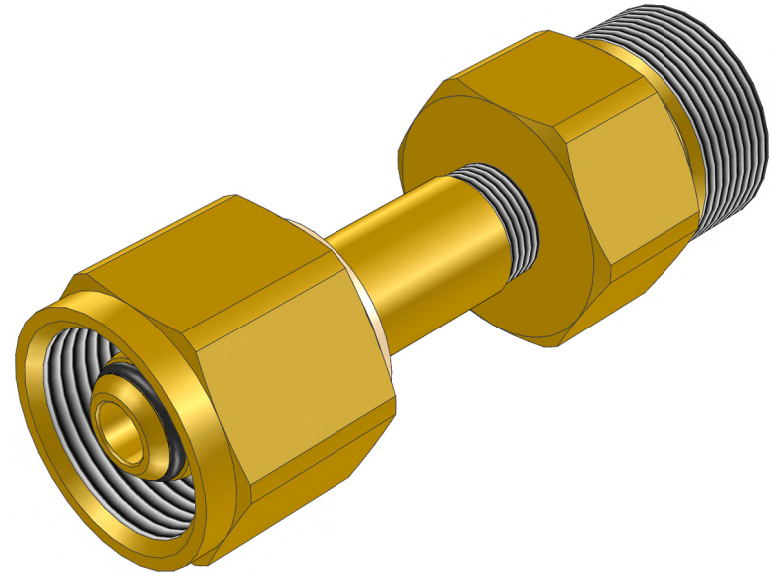

CGA-540N
.903-14 NGO-RH

1 1/8 Hex
Wrench

1 1/8 Hex
Wrench

DIN-477-9S
G 3/4-14 BSPP
(1.037)-14
[26.4mm]

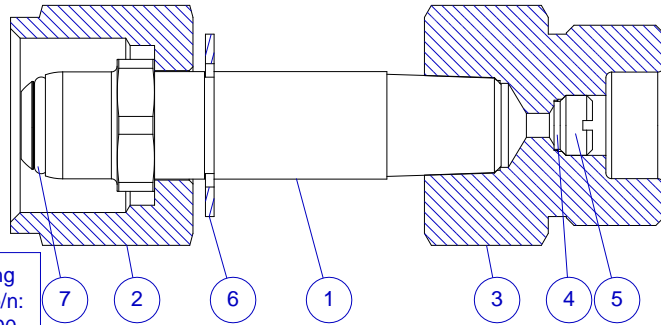

Item #7 O-Ring
Replacement p/n:
09001-0011-90

GENERAL SPECIFICATIONS

Material: UNS C36000 (CDA-360) Brass
 Weight: 10 oz [285 g]
 Operating Pressure: 3000 PSI
 Temp Range: -50°F to +130°F [-45°C to +55°C]
 Clean: For Oxygen Service

UNLESS OTHERWISE SPECIFIED, DIMENSIONS ARE IN INCHES. TOLERANCES ARE:
 0.X ±0.015
 0.XX ±0.010
 0.XXX ±0.005

ANGLES ± 3°
 FRACTIONS ± 1/64

INTERPRET GD&T PER ASME 14.5

THIRD ANGLE
PROJECTION

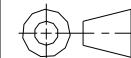

DO NOT SCALE
DRAWING

DRAWN SGO
2018-07-20

CHECKED

ENGINEER

APPROVED



MOUNTAIN HIGH E&S CO.
REDMOND, OR. USA

THIS DOCUMENT AND ALL TECHNICAL DATA HEREON DISCLOSED ARE PROPERTY OF MOUNTAIN HIGH E&S CO. AND SHALL NOT BE USED, RELEASED OR DISCLOSED IN WHOLE OR PART WITHOUT WRITTEN PERMISSION FROM MOUNTAIN HIGH E&S CO. THIS DOCUMENT MUST BE RETURNED TO MOUNTAIN HIGH E&S CO. IMMEDIATELY UPON REQUEST.

DWG TITLE
**Customer Drawing, Transfiller Adapter,
CGA-540N to DIN-477-9S [SCD]**

DWG NUMBER
5SGSE-1023-00

CAD FILE 00GSE-1023-00\$-1 INV. PART NUMBER 00GSE-1023-00 PROD. NAME TA-540N-DIN9S

DWG SCALE DWG SHEET 1 OF 1 DWG SIZE A 11x8 1/2

Ref	Qty	Description
1	1	CGA Nipple
2	1	CGA Nut
3	1	DIN Socket
4	1	Filter
5	1	Hollow Setscrew
6	1	Retaining Ring
7	1	O-Ring

Insert #: 5IGSE-1023-00